



High-temperature air-to-water heat pumps

NEW

Designed to *replace conventional boilers and furnaces* and *produce domestic hot water*

Water outlet temperature:
+65°C at -12°C
Current limiter included in
single-phase models



AQUALIS CALEO



Heating capacity: 13.7 to 19.4 kW

USE

- Aqualis Caleo high-temperature air-to-water heat pumps are specially designed for use in new and renovated homes.
- The high temperature regimes (+65°C at -12°C) allow any type of terminal unit (radiators, radiant floor heating and cooling systems and fan coil units) to be connected. Once installed, they can be used in conjunction with or to replace a boiler.
- When combined with a hot-water tank and a buffer tank, they provide complete autonomy and offer comfort and real energy savings.

DESCRIPTION

- EVI (enhanced vapour injection) scroll compressor
- Stainless-steel brazed plate water-cooled heat exchanger
- Copper tube coil with aluminium fins
- Starting current limiter as standard on single-phase model, as required by French standard NF C 15-100
- Propeller fans
- Control: Microprocessor-controlled control unit with Microconnect control (two-wire connection)
- Water circuit with accelerator pump
- Recyclable UV-stabilised plastic casing
- Meets EN 60-335, EN 378-2 and NF C 15-100 standards
- Meets 89/336/EEC (electromagnetic compatibility) and 97/23/EC (pressure equipment) directives

QUICK SELECTION TABLE

Aqualis Caleo		R407C					
		60H		60HT		70HT	
		45/40	35/30	45/40	35/30	45/40	35/30
Heating capacity	kW	13.72	13.66	13.9	13.67	19.50	19.37
Power input	kW	4.32	3.75	4	3.30	5.88	4.85
COP		3.18	3.64	3.48	4.14	3.30	4
Sound level	dB(A)	47		47		55	
Power supply voltage		230 V - 1-ph - 50 Hz + Earth + N			400 V - 3-ph - 50 Hz + Earth + N		

NOTE: Quick selection table based on Eurovent conditions. TEMPERATURE REGIME: 45/40°C - TEMPERATURE REGIME: 35/30°C - AIR - DB 7°C/WB 6°C

COMPONENTS

Hermetic compressor

- EVI scroll compressor (enhanced vapour injection). Two scrolls (one fixed and one orbiting).
- Built-in electric motor cooled by suction gases.
- Motor protected by winding sensor.

Water-to-refrigerant heat exchanger

- Brazed plates.
- Intermediate and end plates made of AISI 316 stainless steel.
- High-performance, optimised plate patterns.
- Thermal insulation.

Air-cooled heat exchanger

- Bent coil made of copper tubes and aluminium fins.

Standard accessories

- Reversing valve.
- Sound attenuator on discharge.
- Liquid tank.
- Bi-flow expansion valve.
- Dryer.

Electrical panel

- Box conforms to EN 60335 standards.
- Protected control circuit.
- Starting current limiter (single-phase models - French standard NF C 15-100).
- Compressor motor contactor.
- Main earth connection.
- Electronic control unit with microprocessor for:
 - Boiler-heat pump switchover mode: managed automatically by the control system via a setting that can be adjusted based on the outdoor temperature.
 - Monitoring of operating settings.
 - Temperatures displayed on terminal:
 - Water settings in terminal unit mode
 - Room temperature in floor mode (radiant floor heating).

- Unit control
- Two-wire remote-control terminal control.
- ON/OFF input control (two inputs: automatic/load shedding, heating/absence).
- 5-minute short-cycle protection.

Safety and control devices

- High-pressure safety switches.
- Frost protection sensor (exchanger refrigerant outlet).
- Water supply and water return sensors (on exchanger).

Built-in hydraulic module

- Manual air bleed valve.
- Multi-speed accelerator pump.
- Differential water pressure switch.

Options (for installation on site)

- Insulated flexible connections.
- Anti-vibration mounts.
- Screen filter kit with shut-off valves.
- Charging kit.
- Loop heater.

HYDRAULIC MODULE PRINCIPLE DIAGRAM

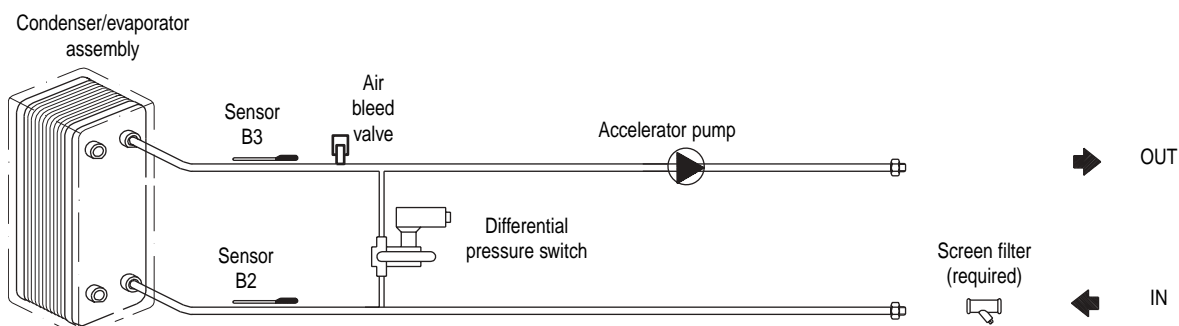



High-temperature air-to-water heat pumps

OPERATING LIMITS

Hot water production

Minimum water return temperature for warm-up: +5°C

Minimum water return temperature during operation:

- pure water = +20°C (radiant floor)
- = +25°C (TU or radiators)

Maximum water inlet temperature: +60°C

Required water flow rates

Aqualis Caleo	60H	60HT	70HT
Minimum flow rate (m³/h)	2	2	2.3
Nominal flow rate, heating mode (m³/h)	2.4	2.4	3.3

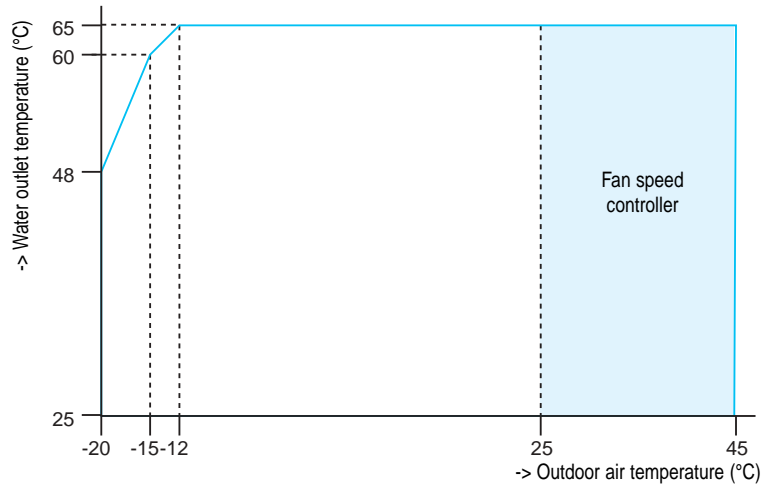

HEATING CAPACITIES

Aqualis Caleo	Out. Air Temp. °C	HOT WATER OUTLET TEMPERATURE (°C)																			
		25		30		35		40		45		50		55		60		65			
		Pi kW	Hc kW	Pi kW	Hc kW	Pi kW	Hc kW	Pi kW	Hc kW	Pi kW	Hc kW	Pi kW	Hc kW	Pi kW	Hc kW	Pi kW	Hc kW	Pi kW	Hc kW		
60H	-20	2.6	6.4	2.9	6.6	3.1	6.8	3.6	7.0	4.0	7.2	4.5	7.2								
	-15	2.7	6.6	3.0	7.0	3.3	7.5	3.7	8.0	4.0	8.5	4.3	8.4	4.7	8.0	5.5	7.4				
	-10	2.9	7.4	3.1	8.0	3.4	8.4	3.7	8.6	4.1	8.7	4.4	8.5	4.8	8.4	5.7	8.3	5.5	8.3		
	-5	3.0	9.1	3.3	9.0	3.5	9.2	3.8	9.5	4.2	9.8	4.5	9.7	4.8	9.5	5.8	9.1	5.6	9.0		
	0	3.1	10.8	3.4	11.0	3.7	11.5	4.0	11.5	4.3	11.6	4.7	11.5	5.0	11.0	5.8	10.3	5.7	9.7		
	5	3.2	12.6	3.5	12.8	3.8	13.0	4.1	13.2	4.3	13.3	4.9	13.3	5.2	13.1	5.8	12.9	6.3	12.7		
	10	3.2	14.1	3.6	14.3	3.9	14.4	4.3	14.6	4.4	14.9	5.1	14.7	5.4	14.5	5.8	14.4	6.4	14.3		
	15	3.4	14.3	3.8	14.6	4.1	15.1	4.4	15.5	4.5	15.8	5.2	15.7	5.5	15.4	5.9	15.3	6.5	14.9		
	20	3.6	14.6	3.9	15.3	4.2	16.0	4.5	15.4	4.6	17.4	5.4	17.3	5.7	17.1	6.0	17.0	6.6	16.8		
	25	3.7	15.3	3.9	16.1	4.2	17.0	4.6	17.8	4.8	18.7	5.3	18.6	5.8	18.6	6.1	18.1	6.8	17.8		
30	3.7	16.0	4.0	17.0	4.3	18.0	4.7	19.1	5.0	20.4	5.4	20.3	5.9	19.8	6.3	19.4	6.9	19.0			
35	3.8	16.8	4.1	18.1	4.4	19.4	4.8	20.7	5.1	22.0	5.5	22.0	6.0	21.0	6.4	19.7	6.9	19.2			
60HT	-20	2.3	6.4	2.6	6.6	2.9	6.9	3.2	7.1	3.5	7.3	3.9	7.3								
	-15	2.4	6.6	2.7	7.1	3.0	7.5	3.3	8.0	3.6	8.5	4.0	8.4	4.3	8.0	4.6	7.8				
	-10	2.4	7.4	3.0	8.1	3.1	8.4	3.4	8.6	3.7	8.8	4.1	8.7	4.3	8.5	4.7	8.4	5.0	8.4		
	-5	2.4	9.1	3.0	9.3	3.2	9.4	3.5	9.6	3.7	9.8	4.2	9.8	4.5	9.5	4.8	9.3	5.1	9.0		
	0	2.5	10.8	3.1	11.1	3.3	11.5	3.6	11.6	3.9	11.8	4.3	11.7	4.5	11.1	4.9	10.2	5.5	9.8		
	5	2.6	12.7	3.2	12.9	3.3	13.1	3.7	13.2	4.0	13.4	4.3	13.4	4.7	13.2	5.0	13.0	5.4	12.8		
	10	2.7	14.1	3.3	14.4	3.6	14.6	3.9	14.7	4.1	14.9	4.6	14.8	4.9	14.5	5.2	14.4	5.4	14.3		
	15	3.0	14.3	3.3	14.7	3.7	15.1	4.0	15.5	4.3	15.9	4.8	15.8	5.1	15.6	5.3	15.4	5.4	15.1		
	20	3.2	14.7	3.4	15.3	3.8	16.0	4.1	15.6	4.4	17.4	4.9	17.3	5.2	17.1	5.4	17.0	5.8	16.8		
	25	3.3	15.3	3.5	16.2	3.9	17.0	4.3	17.9	4.5	18.7	5.0	18.6	5.3	18.6	5.5	18.2	5.8	18.0		
30	3.4	16.1	3.6	17.0	4.0	18.0	4.4	19.2	4.6	20.5	5.0	20.4	5.4	19.9	5.6	19.4	6.0	19.0			
35	3.5	16.9	3.8	18.2	4.1	19.5	4.5	20.8	4.7	22.1	5.1	22.0	5.4	21.1	5.8	19.8	6.0	19.3			
70HT	-20	3.3	8.9	3.7	9.2	4.1	9.6	4.6	9.9	5.0	10.1	5.6	10.1								
	-15	3.4	9.2	3.8	9.8	4.3	10.5	4.7	11.2	5.1	11.8	5.8	11.7	6.3	11.3	6.9	11.1				
	-10	3.4	10.3	4.2	11.3	4.4	11.7	4.9	12.0	5.3	12.2	5.9	12.1	6.4	12.0	7.0	11.9	7.5	11.9		
	-5	3.5	12.6	4.3	12.9	4.6	13.1	5.0	13.3	5.3	13.6	6.1	13.6	6.6	13.4	7.2	13.1	7.6	12.7		
	0	3.6	15.0	4.4	15.4	4.8	15.9	5.2	16.1	5.6	16.4	6.2	16.3	6.7	15.6	7.3	14.4	8.2	13.8		
	5	3.7	17.7	4.5	17.9	4.7	18.2	5.3	18.3	5.7	18.6	6.3	18.6	6.9	18.5	7.4	18.3	8.1	18.0		
	10	3.8	19.6	4.6	19.9	4.9	20.3	5.5	20.4	5.8	20.7	6.7	20.6	7.2	20.4	7.7	20.1	8.1	20.1		
	15	3.9	19.9	4.7	20.4	5.1	21.0	5.7	21.5	6.2	22.1	7.0	22.0	7.4	21.9	7.8	21.6	8.1	21.2		
	20	4.1	20.4	4.7	21.3	5.2	22.2	5.8	21.6	6.3	24.2	7.1	24.0	7.6	24.0	7.9	23.8	8.6	23.6		
	25	4.3	21.3	4.8	22.4	5.4	23.6	6.0	24.8	6.4	26.0	7.2	25.9	7.8	26.0	8.1	25.5	8.7	25.2		
30	4.4	22.4	4.9	23.6	5.5	25.0	6.1	26.7	6.6	28.5	7.2	28.4	7.8	27.9	8.3	27.2	8.8	26.6			
35	4.5	23.5	5.1	25.3	5.7	27.1	6.3	28.9	6.7	30.7	7.3	30.6	7.9	29.5	8.6	27.7	8.9	27.0			

Hc = Heating capacity

Pi = Compressor power input + control + fan(s)

Power consumption level calculations include defrosting cycles.



PUMP SPECIFICATIONS

Available pressure in system

Aqualis Caleo 60H - 60HT

Static pressure available in unit terminals.

Salmson 25-60 accelerator pump - pure water: +20°C

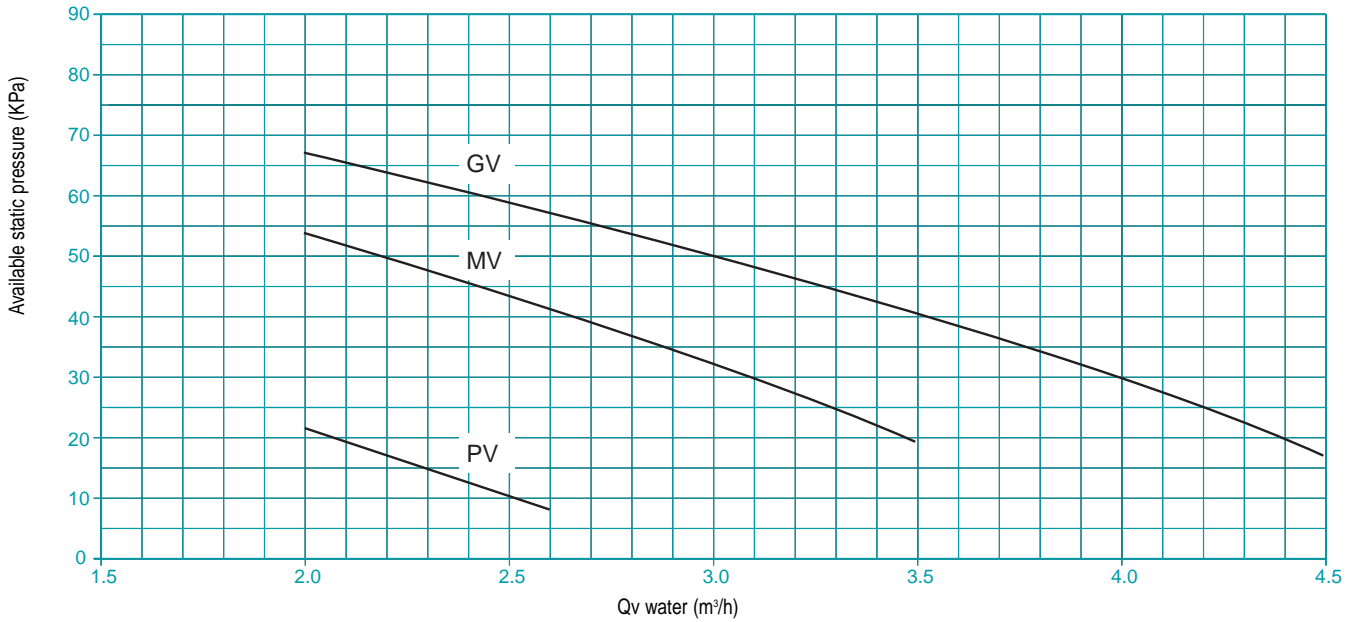

Aqualis Caleo 70HT

Static pressure available in unit terminals.

Salmson 25-60 accelerator pump - pure water: +20°C

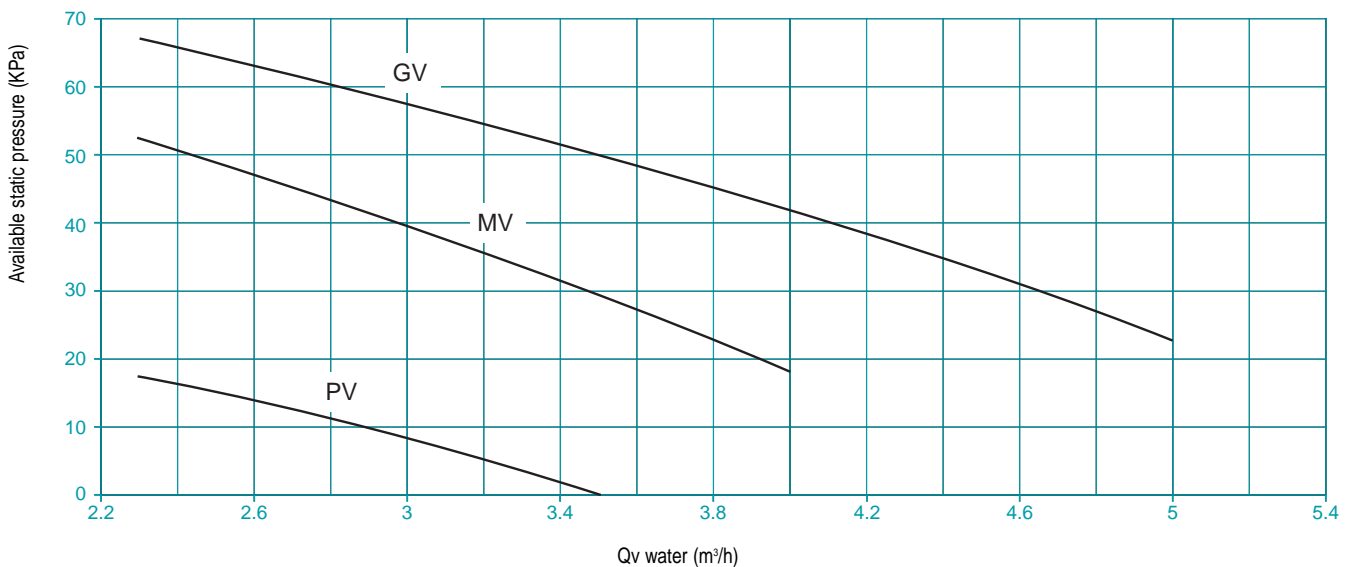



High-temperature air-to-water heat pumps

AQUALIS CALEO

DIMENSIONS

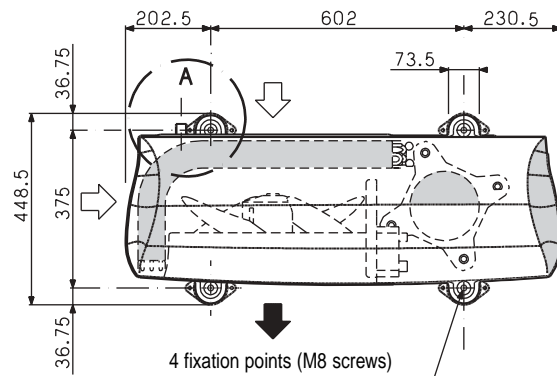
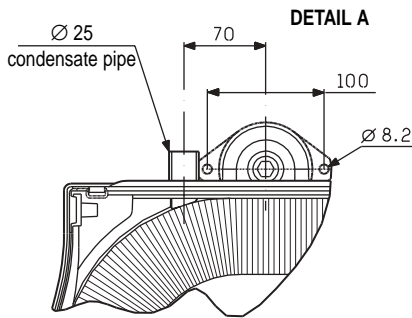
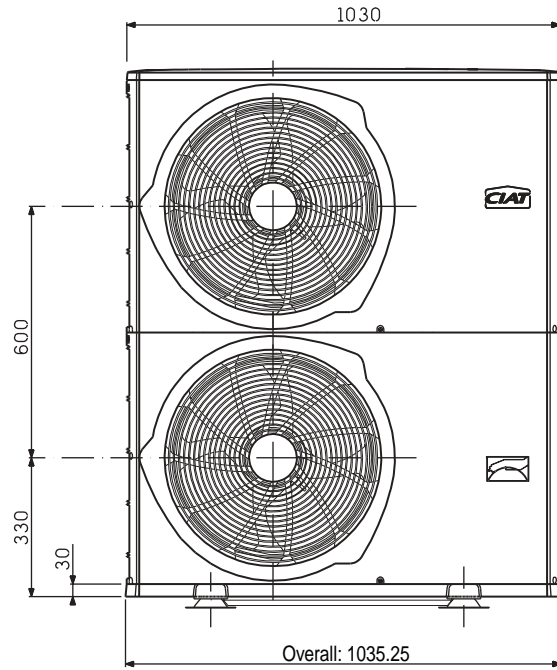
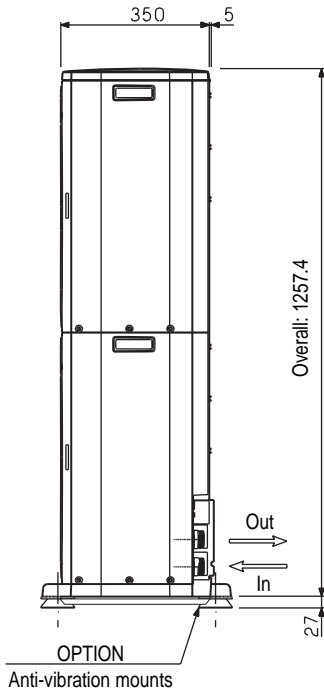

REAR VIEW

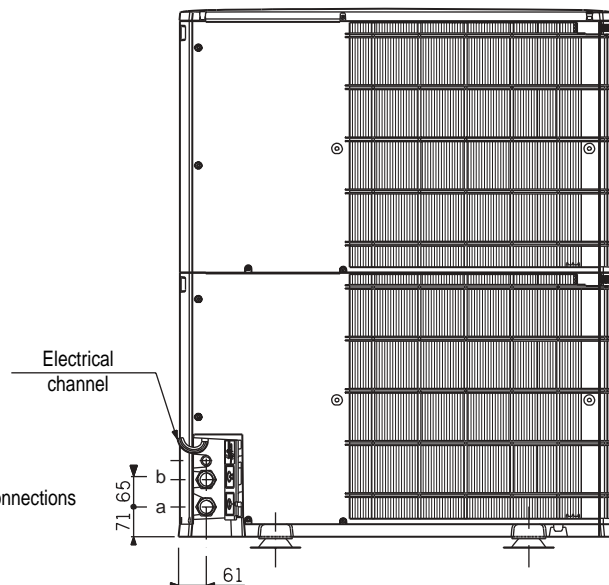

AQUALIS CALEO	Weight (kg)	
	empty	in operation
60H	126	128
60HT	126	128
70HT	143	146

1 1/4" G male water connections
a: In
b: Out



High-temperature air-to-water heat pumps

AQUALIS CALEO

TECHNICAL SPECIFICATIONS

Aqualis Caleo		60H	60HT	70HT	
Compressor	Quantity	1			
	Type	EVI hermetic scroll			
	Capacity control	%	0-100		
	Refrigerant fluid R407C	kg	3.95	3.95	3.95
	Oil capacity (POE)	l	1.89	1.4	1.7
Indoor heat exchanger	Number of circuits	1/1			
	Type	Brazen plates			
	Water content	l	2.76		3.7
Internal hydraulic module	Min. water content of system	l	90	125	
	Number of accelerator pump speeds / Available pressure 40/45°C 7/6°C	kPa	3/62	3/62	3/57
Outdoor heat exchanger	Number of circuits	1/1			
	Type	Coil made of grooved copper tubes with aluminium fins			
	Fan type	Axial			
	Quantity and diameter	2/dia. 450			
	Rotation speed	rpm	718	718	897

ELECTRICAL SPECIFICATIONS

Aqualis Caleo		60H	60HT	70HT	
Electrical power supply		230 V - 1-ph - 50 Hz + Earth + N	400 V - 3-ph - 50 Hz + Earth + N		
Compressor (1)	Max. operating current	A	31	12	14
	Min./Max. rated current	A	0.65/1.1		
Accelerator pump	Min./Max. power consumption	W	120/210		
	Rated current	A	2 x 0.47		2 x 0.74
Fan motor	Power	W	2 x 110		2 x 160
	Control	A	0.18		
Max. unit current	230 V	A	33.2	-	
Entire unit	400 V	A	-	14.22	16.8
Compressor starting current*	A	45	64	70	
C or D curve circuit breaker (not supplied)	Am	40	16	20	
Electrical wiring (not supplied)	mm ²	3G10 (3)	5G6 (2)	5G10 (2)	

- (1) Current corresponds to max. compressor current during operation.
 (2) Cable with 2 or 3 charged PVC conductors for temperatures below 60°C
Note: for other conditions, refer to French standard NF C 15-100
 (3) Cable with 2 or 3 charged PVC/V2-K conductors (high temperature)
Note: for other conditions, refer to French standard NF C 15-100
 * Soft Start System integrated in single-phase units

SOUND LEVELS

Aqualis Caleo		60H	60HT	70HT
Overall level	dB(A)	47	47	55



High-temperature air-to-water heat pumps

SCHEMATIC INSTALLATION DIAGRAM

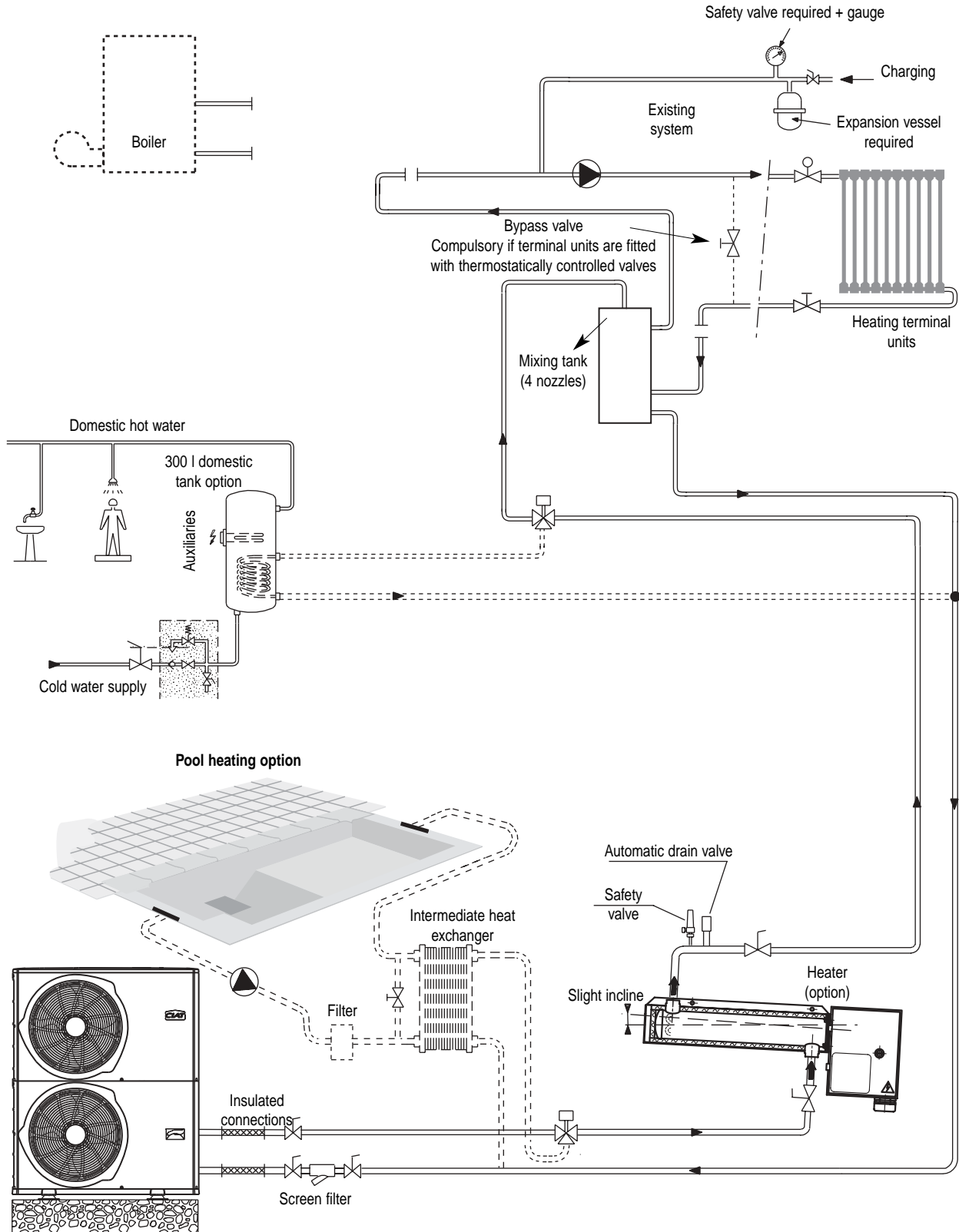

Note: the schematic diagrams herein are provided for information only. Under no circumstances do they constitute actual installation diagrams.



ASSEMBLY RECOMMENDATIONS

Installation

Aqualis Caleo units are designed to be installed outdoors on a home deck/patio or in a garden.

- Nothing should obstruct the air supply over the coil or the fan discharge.
- Carefully consider where to install the unit and choose a location appropriate for the surrounding environment (noise levels, integration on site, etc.).
- Enough clearance should be left around the unit to allow for connections, servicing and maintenance.

Necessary clearance around the unit:

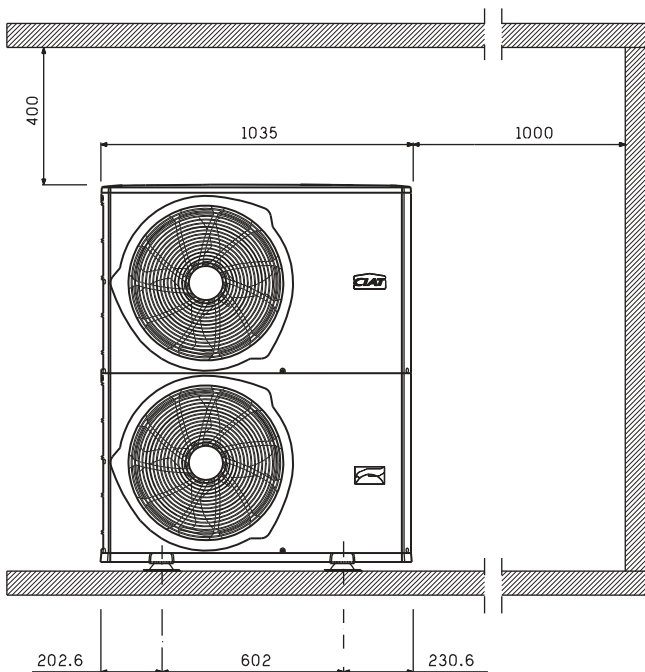

Electrical connections

All the information needed to wire the system is provided on the wiring diagram supplied with the unit. The diagram should be followed to the letter.

Wiring must be performed in accordance with accepted engineering practice and conform to the regulations in force.

A cut-off switch and circuit breaker must be installed on the unit by the fitter.

NOTE: To protect the unit from freezing temperatures, leave it on to allow the water to continue flowing through the water circuit.

Hydraulic connections

Hydraulic connections are to be made in accordance with good engineering practice.

To prevent transmitting noise through the ground or pipes, we recommend using hoses for the hydraulic connections and placing anti-vibration mounts under the unit.

- Place a screen filter with a maximum particle size of less than 600 µm on the water circuit to protect it from fouling.

Commissioning

- Follow the instructions given in our installation and maintenance manuals.

Servicing

- Follow the owner's manual.
- Take out a maintenance contract.

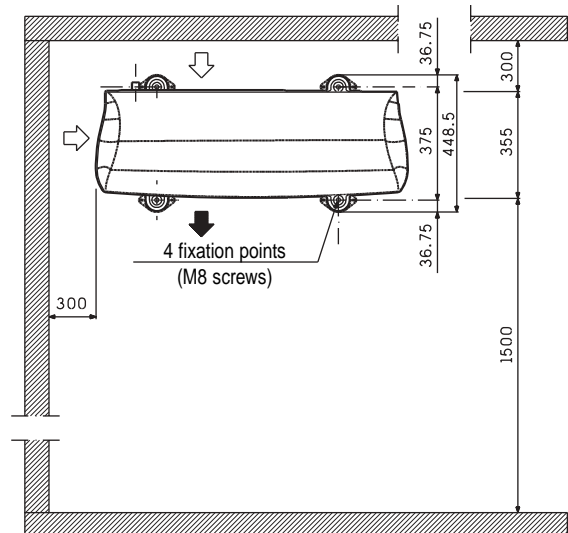

Non contractual document. With the thought of material improvement always in mind, CIAT reserves the right, without notice, to proceed with any technical modification.

Head office & Factories

Avenue Jean Falconnier - B.P. 14
 01350 - Culoz - France
 Tel.: +33 (0)4 79 42 42 42 - Fax: +33 (0)4 79 42 42 10
 e-mail: info@ciat.fr - www.ciat.com



CIAT Service

Tel.: +33 (0)4 79 42 42 90 - Fax: +33 (0)4 79 42 42 13

CERTIFIED ISO 9001
QUALITY SYSTEM



Compagnie Industrielle d'Applications Thermiques - S.A. with a registered capital of 26 000 000 € - R.C.S. Belley B 545 620 114